

SENTRY™

AIR CONTROL OPTIONS

Adjustable

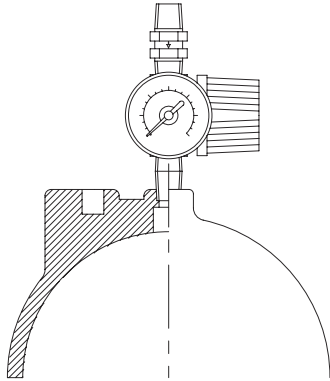

Pulsation Dampeners at Pump Discharge

Adjustable Air Control

The adjustable air control assembly is mounted on a single port with a self-relieving regulator to set dampener pressure and includes a gauge and one-way brass check valve. A compressed air line must be permanently attached to the regulator.

The regulator allows for an easy, convenient method to adjust dampener pressure with system pressure changes. Simply charge the dampener to 80% of system operating pressure and then fine tune for maximum performance.

Maximum Pressure 150 psi (10.3 bar)

Installation

- Locate dampener within ten pipe diameters of pump discharge.
- Connect to a constant source of compressed air. DO NOT USE OXYGEN.
- Charge dampener to 80% of system operating pressure.
- Adjust dampener pressure to minimal pulse level.

Automatic

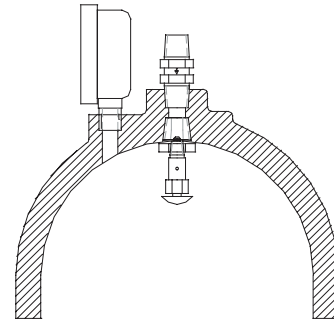

Pulsation Dampeners at Pump Discharge

Automatic Air Control

The automatic air control has a gauge mounted on a side port with an automatic valve assembly on the center port, with a one-way brass check valve connected to an internal poppet valve assembly.

The poppet valve located in the non-wetted portion of the dampener allows for an increase in compressed air pressure to balance an increase in system pressure. As system pressure increases the bladder is pushed further up into the dampener until it makes contact with the internal valve which then opens allowing compressed air to enter the dampener.

The dampener automatically self-adjusts as system pressure increases or decreases, and resets to be ready to start dampening again when the system restarts.

Maximum Pressure 150 psi (10.3 bar)

Installation

- Locate dampener within ten pipe diameters of pump discharge.
- Connect to a constant source of compressed air. DO NOT USE OXYGEN.
- When the pump is started the dampener gauge will read system pressure. No further adjustments are needed.

SENTRY™

AIR CONTROL OPTIONS

Chargeable

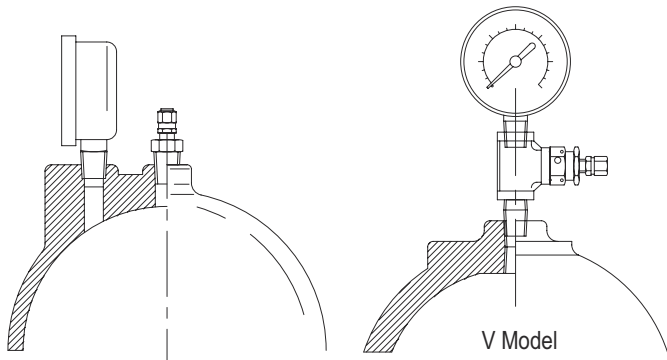

Pulsation Dampeners, Surge Suppressors, Thermal Expansion Chambers and Accumulators

Chargeable Air Control

The standard chargeable model has a gauge and Schrader-type charging valve on separate ports to pressurize and hold dampener pressure. The V Model assembly has a machined stainless steel charging valve and seal for rugged leak-proof operation in corrosive environments.

No permanent source of compressed gas is required. With the gas fill valve the dampener can be manually bled or charged to the required pressure setting.

Used for dampening pulsations in systems using metering, piston and peristaltic/hose pumps, chargeable models are also used as Surge Suppressors, Accumulators and Thermal Expansion Chambers.

Maximum Pressure rating based on model.

Installation

- Locate dampener within ten pipe diameters of pump discharge or valve, depending on use.
- Charge dampener to recommended percentage of system operating pressure with compressed air or clean dry Nitrogen. **DO NOT USE OXYGEN.** (Charging kits available from Blacoh.)

Dampener Charge as % of System Pressure:

- 80% Pulsation Dampener at pump discharge
- 97% Surge Suppressor at quick closing valve or bottom of high vertical run
- 50% Surge Suppressor for pump startup and shutdown

Contact Blacoh for pressure settings for Accumulators and Thermal Expansion Chambers.

J Model

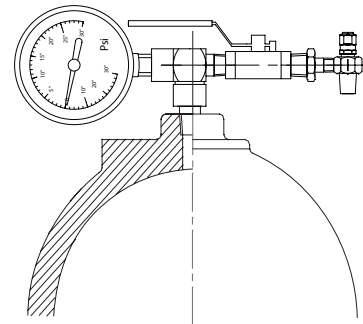

Inlet Stabilizers at Pump Inlet for Suction Lift or Flooded Suction

J Model Air Control

The J Model air control allows for pressure or vacuum settings and is adjustable for suction lift or positive inlet conditions.

The patented J Model air control consists of a compound pressure gauge, a pressure/vacuum tight ball valve and a venturi valve.

Compressed air passes through the venturi valve at high speed creating a low pressure area that evacuates air from the stabilizer creating an internal vacuum. Conversely, when the air flow through the venturi valve is diverted into the stabilizer a pressure charge results.

Inlet Vacuum/Pressure 30 inHg-0-30 psi

Installation

- Locate inlet stabilizer within ten pipe diameters of pump inlet.
- Use a compressed air line and air chuck to pressurize or create a vacuum. **DO NOT USE OXYGEN.**
- For suction lift, vacuum charge to 5-7 inHg. For flooded suction charge to 50% of static inlet pump pressure.



Please contact our Asia Pacific distributor:

H2O Rx

Phone: 0409 784 236 or 0421 795 353

Email: info@h2orx.com.au PO Box 748, Lane Cove NSW 1595

www.h2orx.com.au